



VEGA
A B S O L U T E

GATEWAY

BS-1.2 / BS-2.2

USER MANUAL

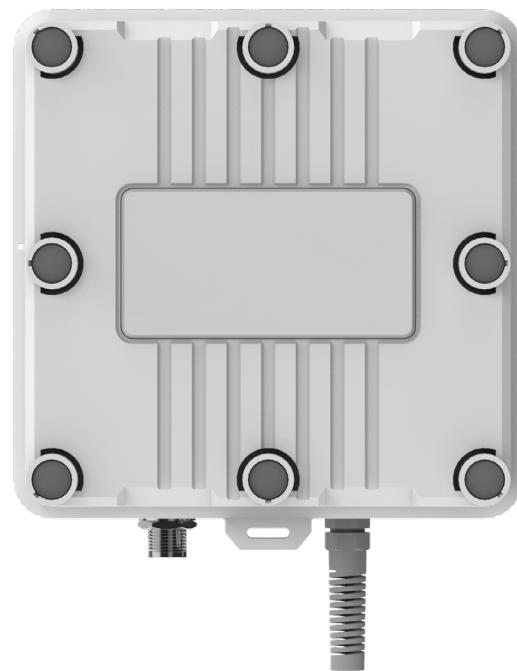

DOCUMENTATION REVISION	BS REVISION	SOFTWARE VERSION
36	6 and higher	1.0

CONTENT

INTRODUCTION 4

1 DEVICE PURPOSE AND OPERATION PRINCIPAL 5

2 SPECIFICATION 6

3 OPERATION 9

 Device Appearance 9

 Control instruments – buttons and switches 14

 SIM card installation at the BS-2.2 15

 Indication 17

 Antenna mounting recommendations 18

 Mounting Recomendations 19

 Maintenance recommendations 22

4 CONFIGURING OF THE GATEWAY WITH WEB-INTERFACE 24

 Interface launch – the operation begining 24

 Gateway software updating 30

5 CONFIGURING OF THE GATEWAY WITH TERMINAL PROGRAM 31

 Gateway connecting to the computer – the operation begining 31

 Operation with the configuration file 35

 Configuration of a static IP-adress for the gateway 39

 BS-2.2 Gateway setting up for LTE operation 42

 Recommendations for gateway using in white IP net 45

6 SAFE OPERATION RECOMMENDATIONS 47

General recommendations.....	47
ELECTRICAL SAFETY	48
SAFETY RULES IN CASE OF DAMAGE TO THE ENCLOSURE.....	49
RADIATION INFORMATION.....	49
7 STORAGE AND TRANSPORTATION REQUIREMENTS	50
8 CONTENT OF THE PACKAGE	51
9 WARRANTY.....	52

INTRODUCTION

This manual is designed for Vega BS-1.2 and Vega BS-2.2 gateways (hereinafter – the gateway) manufactured by Vega-Absolute OOO and provides information on powering and activation procedure, control commands and functions of the gateway.



Gateways can be supplied without software by request

This manual is targeted at specialists familiar with installation work fundamentals for electronic and electrical equipment.



**It is forbidden to use the device in case of any malfunctions
In the event of a malfunction, contact the manufacturer's technical support team**

In order to prevent possible personal injury and/or equipment damage, it is strongly recommended that you read the section "Recommendations for Safe Operation" before setting up and operating the equipment.



The gateway shall be installed and adjusted by qualified specialists to ensure proper operation of the device

Vega-Absolute OOO reserves the right to make changes to the manual related to the improvement of equipment and software, as well as to eliminate typos and inaccuracies, without prior notice.

1 DEVICE PURPOSE AND OPERATION PRINCIPAL

Vega BS gateway is designed to deploy LoRaWAN® network within 863-870 MHz frequency band.

The gateway operates with Linux operating system and is supplied with pre-installed Packet forwarder software.

The gateway is powered and communicates with the server via the Ethernet channel.

The device is configured through Ethernet with SSH protocol either via gateway web-interface or while USB connection with the computer. When gateway is connected via SSH or USB it may be configured with any terminal program (e. g. PuTTY).

Vega BS-2.2 gateway have a GSM/LTE module with the ability to install two Nano-SIM which provides an additional communication channel with a network server and a GPS/GLONASS module for determining the location of the gateway.

2 SPECIFICATION

Model	BS-1.2	BS-2.2
MAIN		
GPS/GLONASS module	no	yes
GSM modem	no	yes
Server communication link	Ethernet 10/100 Base-T	Ethernet 10/100 Base-T, GSM LTE ¹
Operating system	Linux	
USB-порт	yes	
Operating	-40...+70 °C	
LORAWAN®		
Number of LoRa channels	8	
Frequency band	863-870 MHz	

¹ FDD-LTE (Cat.1): B1/B3/B5/B7/B8/B20

GSM/GPRS/EDGE: 900/1800MHz

Receiver sensitivity	-141 dBm (при: LoRa, SF12, 125 kHz BW)			
Power output	up to 500 mW			
Power output by default	25 mW			
Antenna connector	N-Type female			
Data transfer rate	Data transfer rate (DataRate)	Configuration	Data transfer rate, bit/s	Signal/noise (SNR) of the minimal demodulation level (dB)
	DR0	LFM: SF12 / 125 kHz	250	-20
	DR1	LFM: SF11 / 125 kHz	440	-17,5
	DR2	LFM: SF10 / 125 kHz	980	-15
	DR3	LFM: SF9 / 125 kHz	1760	-12,5
	DR4	LFM: SF8 / 125 kHz	3125	-10
	DR5	LFM: SF7 / 125 kHz	5470	-7,5
	DR6	LFM: SF7 / 250 kHz	11000	-
DR7	FSK: 50 kbit/s	50000	-	

Radio coverage in restrained urban conditions	up to 5 km
Radio coverage within line of sight	up to 15 km
POWER	
Power consumption	up to 10 W
Power supply	Passive PoE 4,5(+), 7,8(-) 15 W
CASE	
Housing dimensions	192 x 183 x 75 mm
Ingress protection rating	IP67
Mounting	mast supports

3 OPERATION

DEVICE APPEARANCE

Gateway Vega BS is represented in strong case and compliant with a IP67 code. On the back side there is a mount for mounting on masts using metal clamps.

IP67

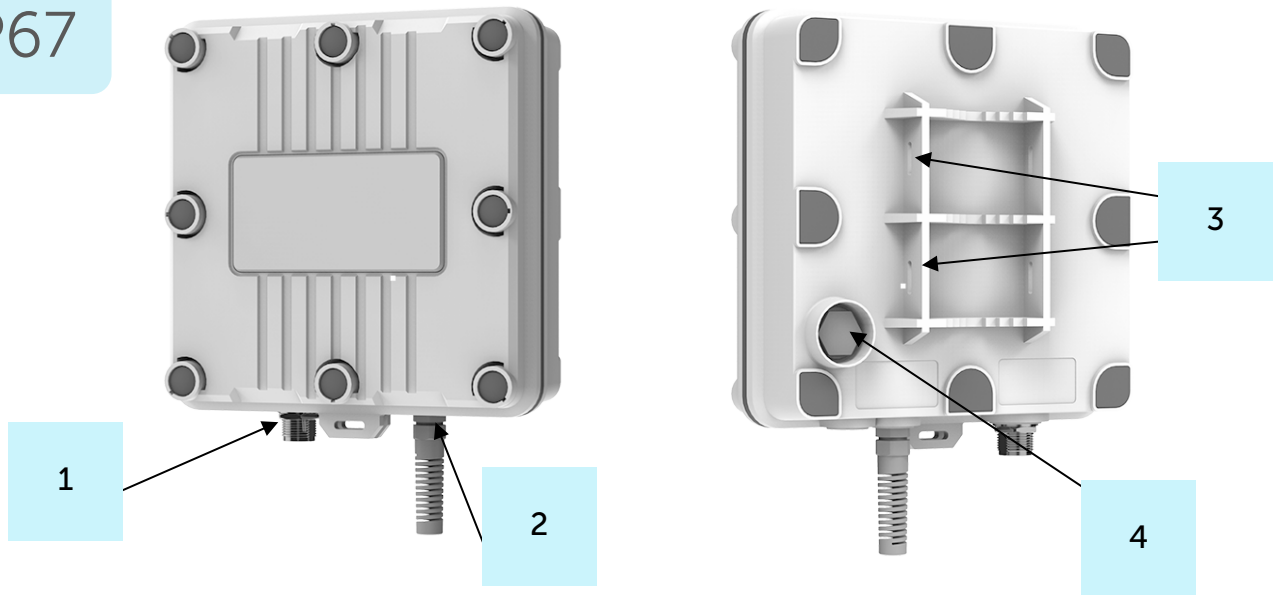

- 1 – N-connector for external antenna
- 2 – cable gland (would be one or two)

- 3 – mount for mounting on masts
- 4 – protective vent

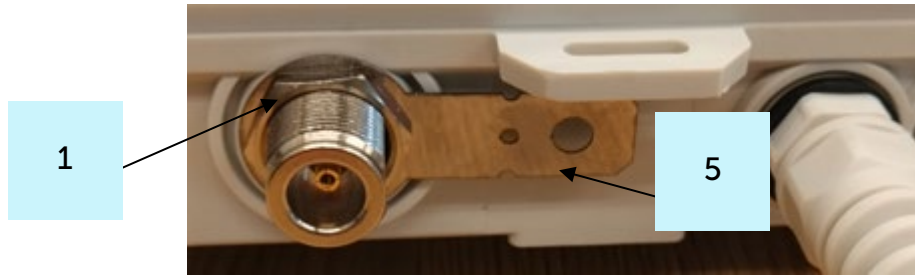

5 – ground connection pin

The case is equipped with a **hermetic gland** of M12 size for round cable \varnothing 5-6 mm. A sealant is installed inside the gland, ensuring compliance with the declared Ingress Protection rating of the device case. Also, sealant is placed on the perimeter of case between two case parts. Removing the sealant can lead to moisture entering the gateway case. **Waterproof protective vent** serves to equalize the air pressure inside and outside the case.

The gateway terminal board has control and indication instruments, input, and output interfaces.

Location of elements on the board of the gateway BS-1.2

- 6 – 8P8C connector
- 7 – additional power connector
- 8 – slot for micro SD-card
- 9 – antenna connector
- 10 – group of indicators
- 11 – service switches

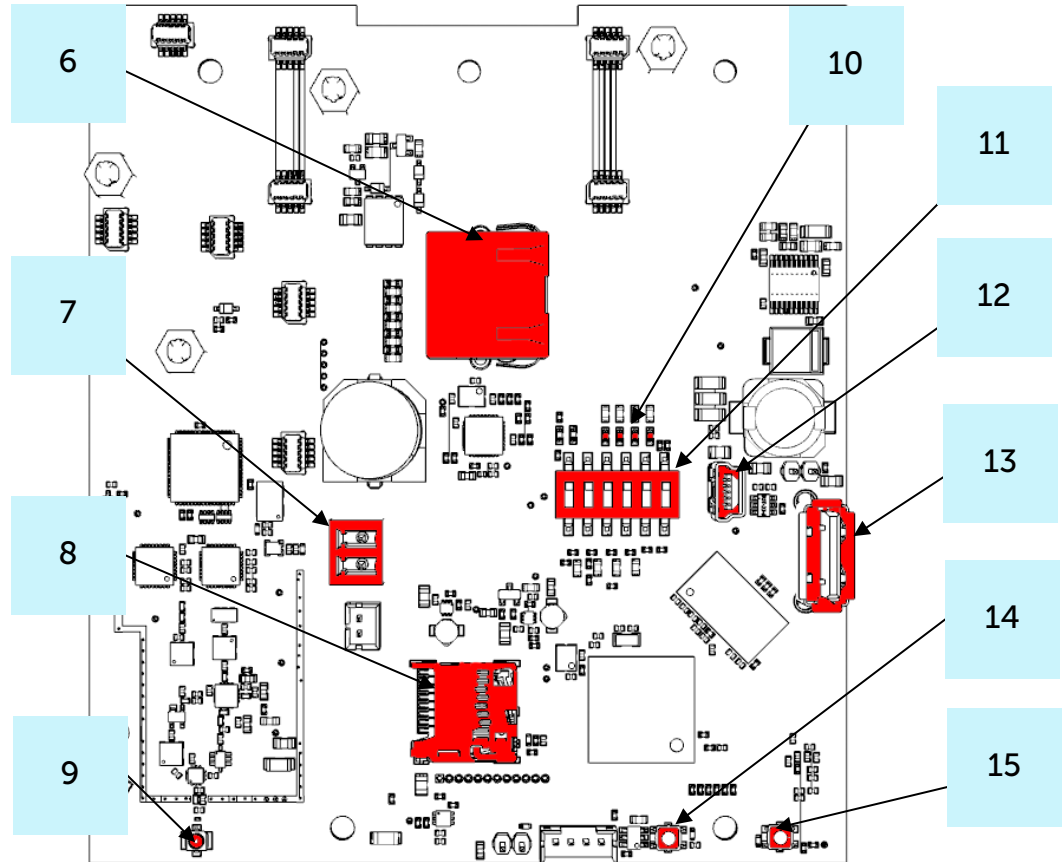

- 12 – mini USB port for connection to the computer
- 13 – USB host for connection external devices

- 14 – BS-Dashboard Web-interface launching
- 15 – gateway reset button

Location of elements on the board of the gateway BS-2.2

16 – SIM1

17 – 8P8C connector

18 – additional power connector

19 – slot for micro SD-card

20 – antenna connector

21 – SIM2

22 - group of indicators

23 – service switches

24 – mini USB port for connection to the computer

25 – USB host for connection external devices

26 – gateway reset button

27 – BS-Dashboard Web-interface launching

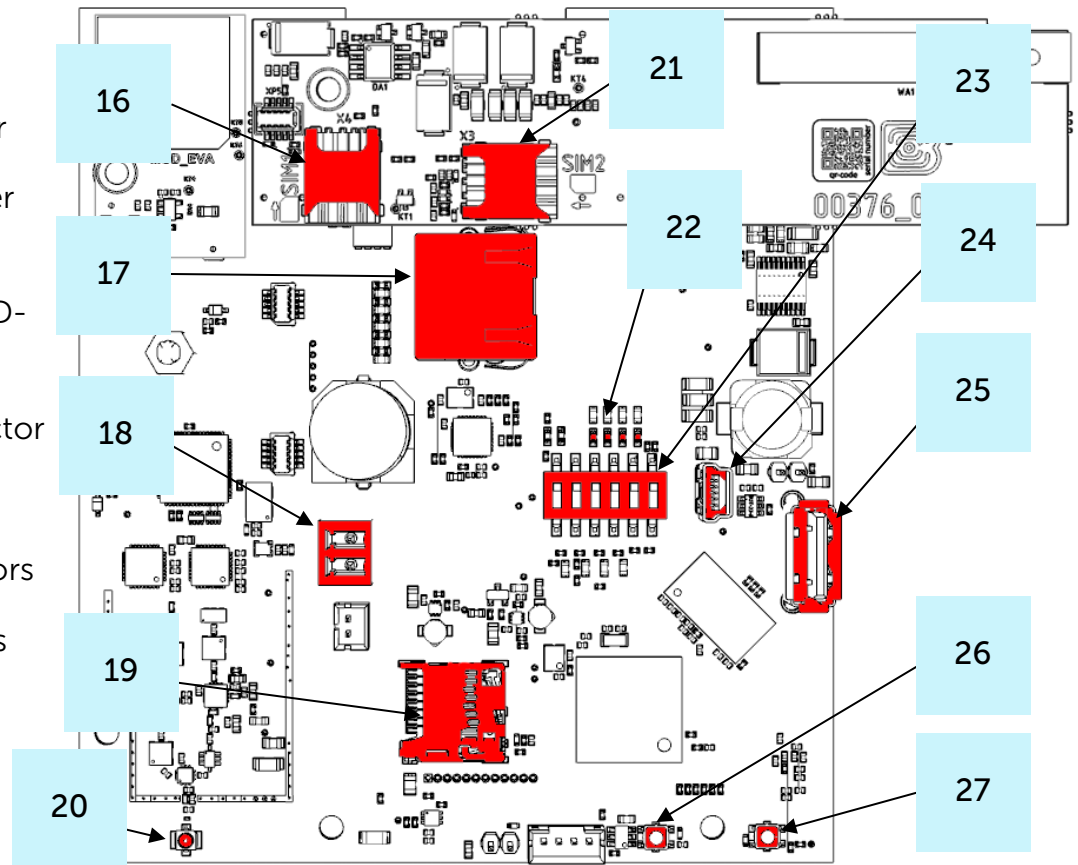

The gateway is connected to the network with an 8-core network cable (twisted pair) through 8P8C connector on the board. Cable shall be crimped in compliance with T568A and T568B standards. Contacts are numerated from 1 to 8 in order right-to-left.

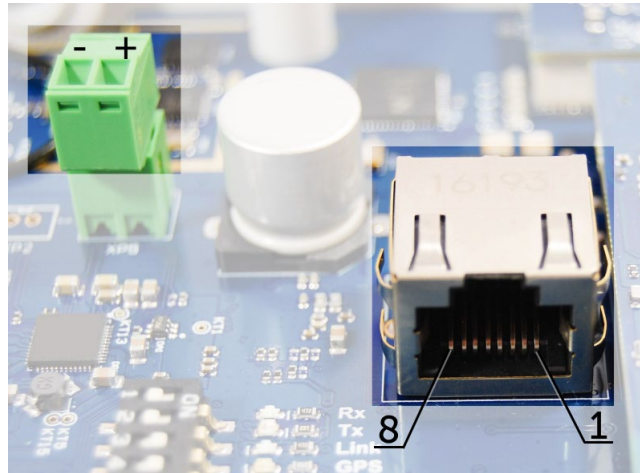

Colors are shown for cable T568B:

Contact number	Color	Designation
1	Orange-and-white	TD+ signal
2	Orange	TD- signal
3	Green-and-white	RD+ signal
4	Blue	Power
5	Blue-and-white	Power
6	Green	RD- signal
7	Brown-and-white	Ground
8	Brown	Ground

There is an additional power connector on the board. It can be connectable only when power contacts 4, 5 and 7, 8 in the network cable are disabled. Permissible power voltage is 12-48 V. Minimum power is 10 W.

CONTROL INSTRUMENTS – BUTTONS AND SWITCHES

There are two buttons on the gateway board. **BT1** launches BS-Dashboard Web-interface. Press **RST** button for the gateway instantaneous rebooting.



In addition, there are **service switches** on the board used to select the download option of the firmware image: from internal memory, from the SD card or via USB-host from the computer. The switches are only for service conditions. In operating mode switches shall be disable, see picture below.

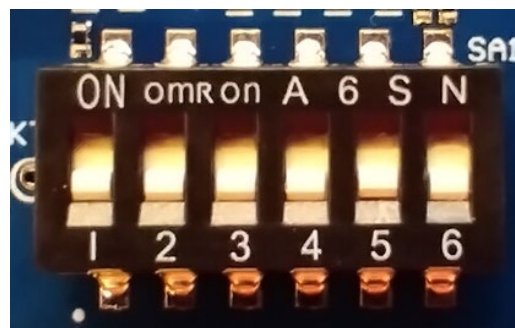

SIM CARD INSTALLATION AT THE BS-2.2

Vega BS-2.2 gateway includes a GSM/LTE module, which is placed on the main board.

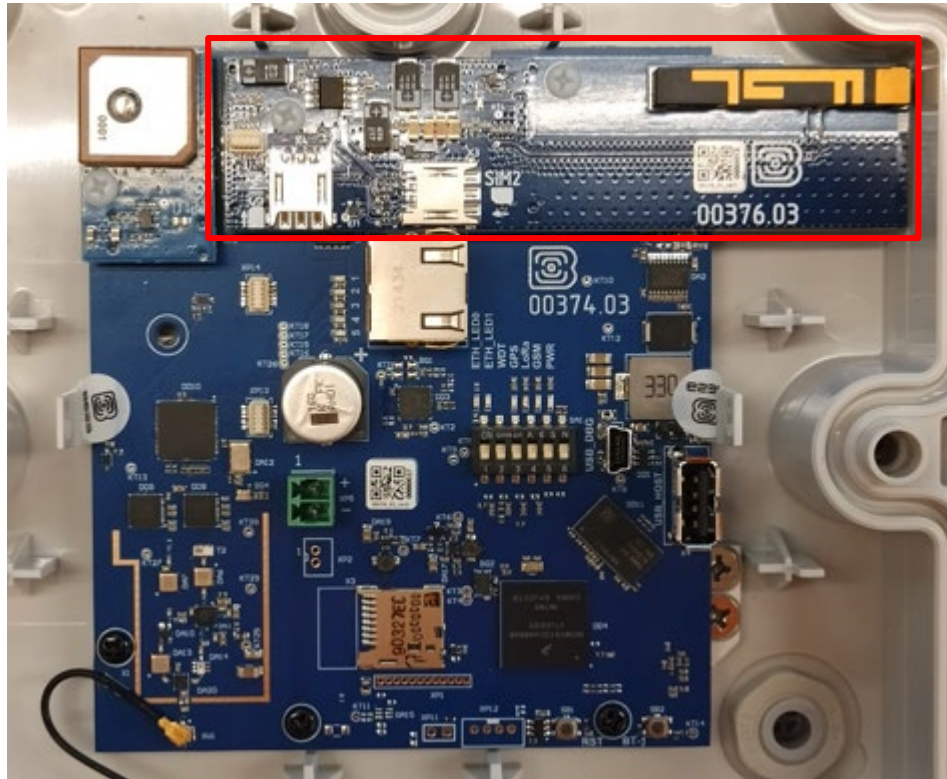

The SIM card must be installed at a temperature not lower than room temperature. If the device was in low temperatures, then before installing the SIM card, you must first keep the device at room temperature for several hours.

The gateway uses 2 nano-SIM cards. The SIM card slots are located on the top surface of the module.

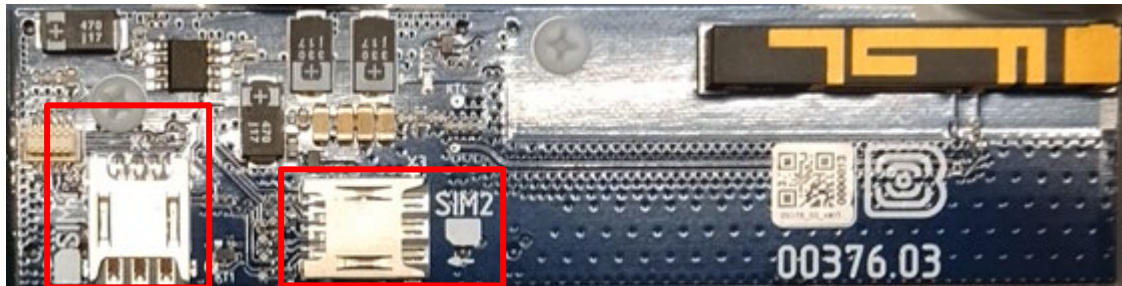

INDICATION

There is a **group of LED indicators** on the terminal board; their signals showing in the table below. They indicate operation of different systems: power (on / off), visibility of GPS satellites, GSM modem (on / off), operation of the LoRa signals processing program (Packet forwarder on/off), Ethernet activity.

LED	Color	Indication
ETH_LINK	Green	<i>Flashes</i> – activity via Ethernet
GPS ²	Blue	<i>Doesn't light</i> – no data from GPS-receiver <i>Flashes</i> – there data exist, but are not valid for use by Packet forwarder <i>Lights</i> – location identified
LoRa	Yellow	<i>Lights</i> – Packet forwarder is started <i>Doesn't light</i> – Packet forwarder is stopped
GSM	Green	<i>Lights</i> – GSM-modem is enabled <i>Doesn't light</i> – GSM-modem is disabled
PWR	Red	<i>Lights</i> – operation system kernel is running <i>Doesn't light</i> – gateway is not powered

² GPS LED indicates the GPS system functioning only while Packet forwarder processing (LoRa LED lights).

ANTENNA MOUNTING RECOMMENDATIONS

The Antenna usually has fasteners for installation on a mast support. To ensure maximum communication range, follow the installation guidelines for the antenna:

1. The antenna should be installed outdoors, preferably on the roof of a building that is 5-7 meters higher than the surrounding buildings. Installing the antenna indoors significantly reduces the sensitivity of the antenna.

2. It is advisable to remove the antenna installation site from the equipment of cellular operators, metal structures and other objects that create a "radio shadow" or a zone of reduced radio signal by 30-50 meters. After all tests have been completed, you can bring the antenna closer to the equipment of the mobile operator if the communication quality is satisfactory.

3. Barriers such as railings and advertising structures can also degrade the radio signal, so it is recommended to place the antenna at a height of at least 3 meters above the roof surface of the building.

4. The gateway must also be installed in close proximity to the antenna - up to the length of the antenna's coaxial wire. An additional increase in the length of the cable between the antenna and the base station will lead to a loss of antenna sensitivity.



For example, 25 meters of RG-58 cable attenuate the signal by 14 dBm, i. e. if transmission power is 14 dBm (25mW), the power on the antenna will be 1mW

5. The antenna directional pattern shall be considered. In the horizontal plane, the antenna has a circular direction, but no vertical direction. Therefore, the quality of communication directly under the antenna will be worse than at some distance from the antenna.

MOUNTING RECOMENDATIONS

The necessary stage for the network deploying including a big quantity of end devices is a radio planning work with nature experiments.

For mounting **you will need**:

- ⦿ cross-shaped screwdriver for gateway assembling;
- ⦿ mounting belts and tool for them;
- ⦿ wire cutters;
- ⦿ a set of tools for cable crimping (stripper, crimper, twisted pair tester, cap, connector);
- ⦿ antenna mounting wrenches;
- ⦿ laptop.

Step by step mounting guide:

1. Setting the gateway is usually carried out in the office (see Network Deployment Manual).
2. Determination of suitable places for mounting at the object with a network tester – radio planning work.
3. Antenna placement and mounting. It's important to place the gateway antenna properly for high-quality signal reception.
4. Connection PoE-injector cable to the gateway. To do this, you need to pass it through the cable gland of the case, and then crimp it with an Ethernet connector.

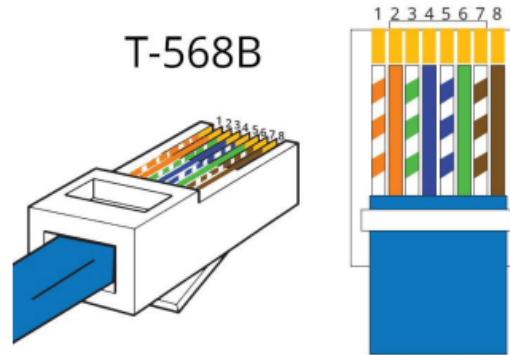

5. Gateway placement on the pole with mounting belts.
6. Power applying on the PoE.
7. By the laptop you can make sure that the device successfully sends the data.
8. Installing and fixing the cover of the gateway with screws, installing the silicone plugs that come with the kit.

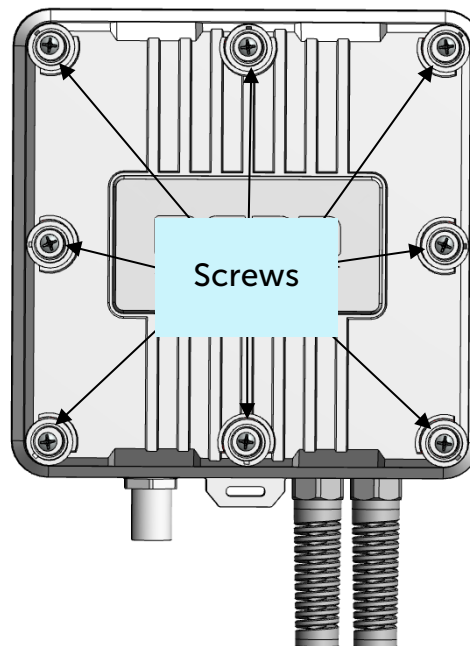



WARNING. The tightening force of the screws must not exceed 0.8 Nm. Exceeding the tightening force may cause the housing to break and lose its tightness

MAINTENANCE RECOMMENDATIONS

To prevent equipment failures during operation, it is recommended to carry out **periodic maintenance** of the gateway. The maintenance period is set depending on the operating conditions and can be **from 6 to 24 months**.

List of possible works during maintenance:

1. Checking the operation status of the gateway.
2. Software updating.
3. Cleaning external elements from dust.
4. Maintenance of mounting, external mounting wires, contact connections.
5. Checking the operation status of the PoE-injector.

The recommended order for each type of work is given in the table below.

Maintenance	Auxiliary materials and tools	Maintenance procedure
Checking the operation status of the gateway	<ul style="list-style-type: none"> ⦿ cross-shaped screwdriver for gateway assembling. 	<ol style="list-style-type: none"> 1. Disassemble the gateway case, remove the cover 2. Make sure that all LEDs from the group of BS status indicators are light according to the table 3. Install the cover in place, assemble the BS
Software updating	<ul style="list-style-type: none"> ⦿ laptop. 	<ol style="list-style-type: none"> 1. Connect to the gateway via the Web-interface 2. Check for an update (exclamation mark next to the "About Device" section) 3. Update software
Cleaning external elements from dust	<ul style="list-style-type: none"> ⦿ microfiber cloth. 	<ol style="list-style-type: none"> 1. De-energize the BS 2. Wipe the outer parts of the BS case with a damp cloth

		<ol style="list-style-type: none"> 3. Wipe the PoE-injector with a damp cloth 4. Wipe the antenna
Maintenance of mounting	<ul style="list-style-type: none"> ⦿ mounting belts and tool for them; ⦿ antenna mounting wrenches. 	<ol style="list-style-type: none"> 1. Carefully check the security of the gateway 2. If necessary, tighten the screws or replace the ties 3. Check the reliability of the antenna mounting
Maintenance of external mounting wires, contact connections	<ul style="list-style-type: none"> ⦿ cross-shaped screwdriver for gateway assembling; ⦿ insulating tape; ⦿ cable glands, wires and cables for replacement; ⦿ a set of tools for cable crimping. 	<ol style="list-style-type: none"> 1. Inspect the external mounting wires of the BS, antenna and PoE-injector for abrasions and damage 2. If necessary, replace the wires or repair the insulation 3. Make sure that the contact connections are tight 4. Make sure that the cable glands are in good condition, and the seal is intact 5. If necessary, replace the cable glands
Checking the operation status of the PoE-injector	<ul style="list-style-type: none"> ⦿ multimeter. 	<ol style="list-style-type: none"> 1. Make sure the PoE-injector LED is green 2. Disconnect the Ethernet cable 3. Measure the voltage at the power outputs of the PoE-injector with a multimeter 4. Make sure the voltage is $48V \pm 1V$

4 CONFIGURING OF THE GATEWAY WITH WEB-INTERFACE

INTERFACE LAUNCH – THE OPERATION BEGINING

Web-interface software consist of two parts:

1. Server's API "BS-Dashboard" which (in depending on received data) transmits current settings, device information and saved new settings at the device memory. API «BS-Dashboard» is available on the port 3001 by default.
2. Client's Web-application operating with server's API "BS-Dashboard" – is developed for visual displaying data, for validation of changes and for sending the settings to save at the device. Client's Web-application is available on the port 80.

"BS-Dashboard" launched by the pressing the button BT1 on the gateway board. It may be changed in the settings. After holding the button in a pressed state during more than 6 seconds the launch begins, which may be continuing about 1 or 2 minutes in depending on the device loading.

For entering to a client's web-application IP-address of the gateway is needed. You can find out it with terminal program (for example, with a free PuTTY program). Part 5 describes in detail how to connect to a gateway with a terminal program. You should enter the command **ifconfig** in terminal window.

```
root@imx6ull-vega-00374-03:~#
root@imx6ull-vega-00374-03:~# ifconfig
eth0      Link encap:Ethernet  HWaddr ae:a6:4a:64:87:b5
          inet addr:10.10.70.193  Bcast:10.10.70.255  Mask:255.255.255.0
          inet6 addr: fe80::aca6:4aff:fe64:87b5/64 Scope:Link
          UP BROADCAST RUNNING MULTICAST  MTU:1500  Metric:1
          RX packets:294017 errors:0 dropped:0 overruns:0 frame:0
          TX packets:159014 errors:0 dropped:0 overruns:0 carrier:0
          collisions:0 txqueuelen:1000
          RX bytes:26463535 (25.2 MiB)  TX bytes:18228264 (17.3 MiB)

lo        Link encap:Local Loopback
          inet addr:127.0.0.1  Mask:255.0.0.0
          inet6 addr: ::1/128 Scope:Host
          UP LOOPBACK RUNNING  MTU:65536  Metric:1
          RX packets:9482 errors:0 dropped:0 overruns:0 frame:0
          TX packets:9482 errors:0 dropped:0 overruns:0 carrier:0
          collisions:0 txqueuelen:1000
          RX bytes:474100 (462.9 KiB)  TX bytes:474100 (462.9 KiB)

root@imx6ull-vega-00374-03:~# █
```

The next step is to open a browser and enter IP-address in the address bar. If the “BS-Dashboard” server is launched successfully then the authorization page for login into the client’s Web-application will appear.



If there is no connection to Web-interface and authorization page is not appearing, then you need to add port number 80 to IP address of the gateway in the address bar.

It may look like this, for example: <http://192.168.1.228:80>

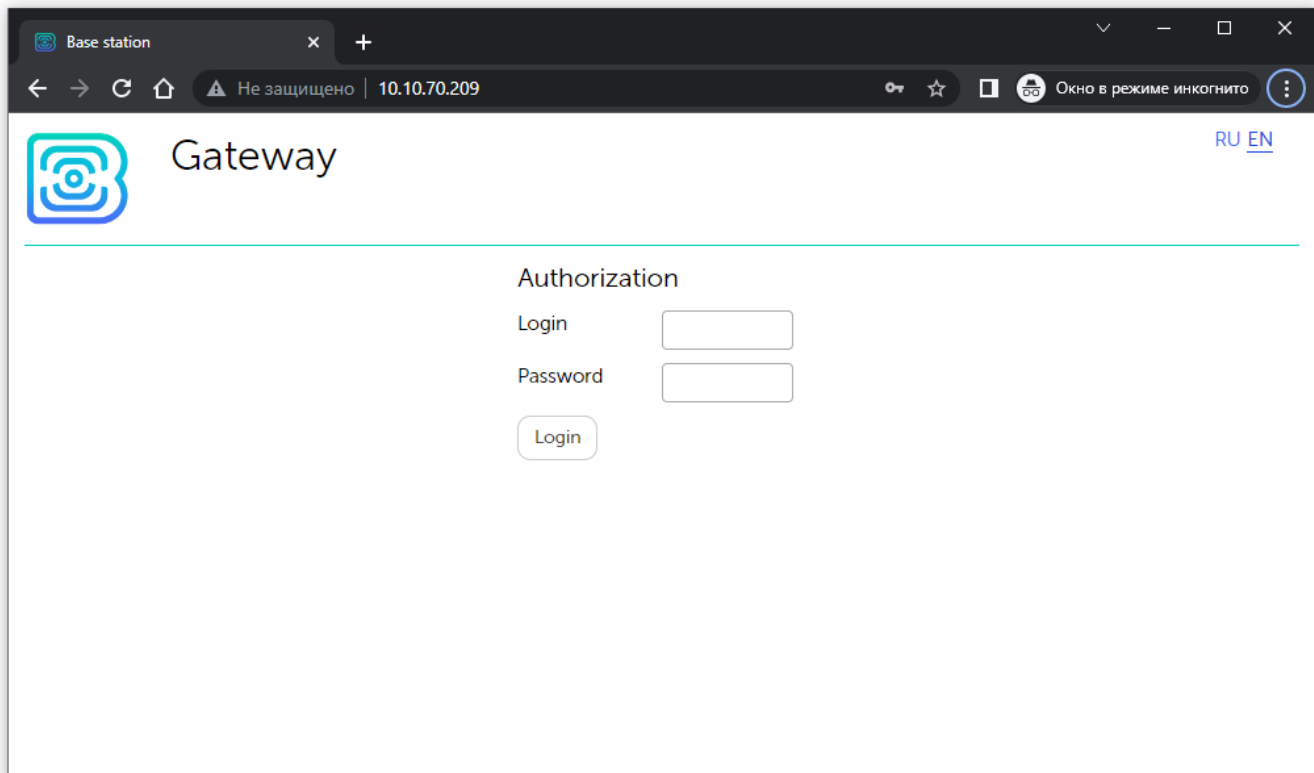

After entering login and password of the gateway (**root/temppwd** or **admin/admin** by default) gateway's Web-interface page appears.

At the top of the page is the name of the menu section in which you are currently.

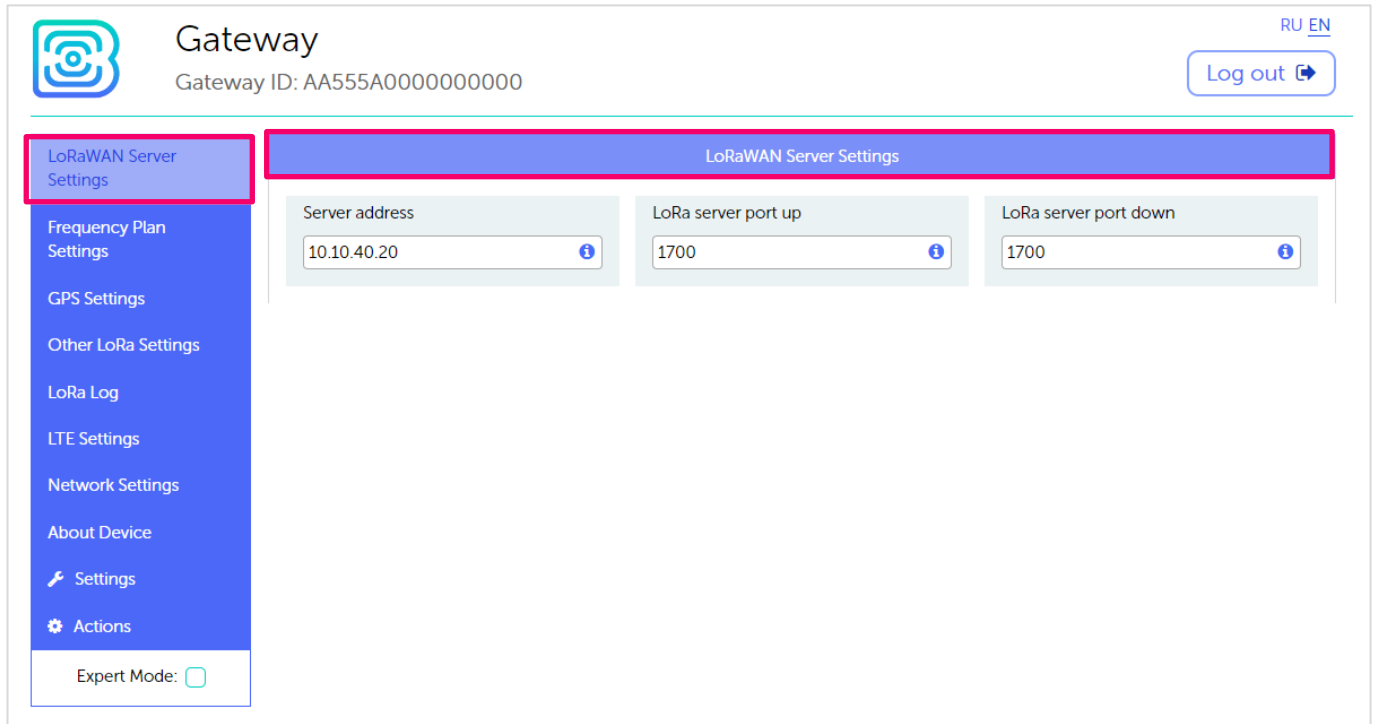

The screenshot displays the Gateway web interface. At the top left is the Gateway logo and the title "Gateway". Below the title is the Gateway ID: AA555A0000000000. In the top right corner, there are links for "RU EN" and a "Log out" button. A left-hand navigation menu is visible, with "LoRaWAN Server Settings" highlighted in blue. The main content area is titled "LoRaWAN Server Settings" and contains three input fields: "Server address" with the value "10.10.40.20", "LoRa server port up" with the value "1700", and "LoRa server port down" with the value "1700". Each input field has a small information icon (i) to its right. At the bottom of the navigation menu, there is an "Expert Mode" toggle switch, which is currently turned off.

If the Web-interface is launched by pressing the button, then when the gateway is restarted, it will become unavailable again. For the Web-interface to always be available, you need to change the server startup settings. To do this, go to the "Settings" menu, then "Manager Settings" and in the "BS-Dashboard Server Startup Method" field change the value to "Always On". After that, be sure to click the "Save" button so that the settings go to the gateway.

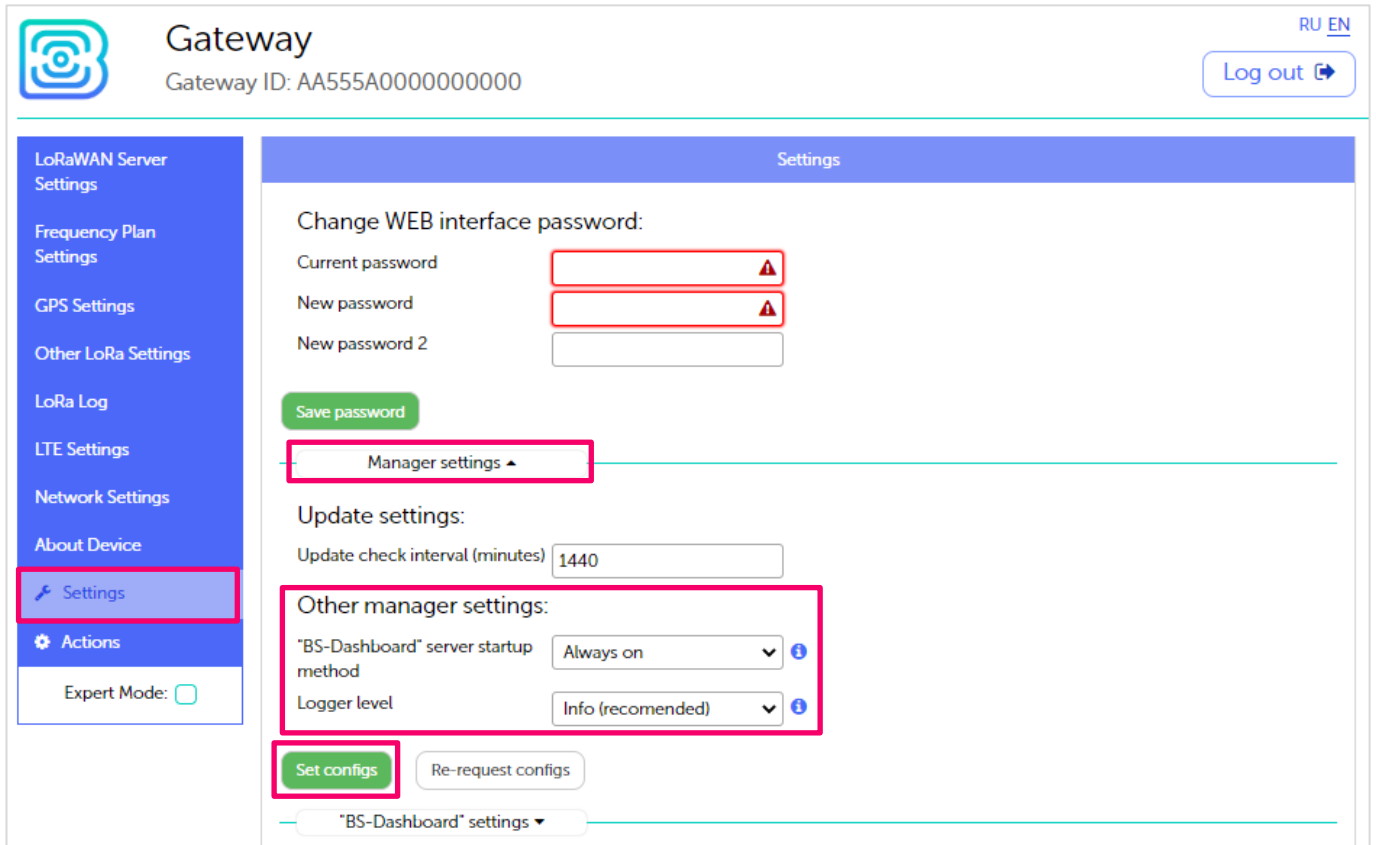

Gateway

Gateway ID: AA555A0000000000

RU EN

Log out

LoRaWAN Server Settings

Frequency Plan Settings

GPS Settings

Other LoRa Settings

LoRa Log

LTE Settings

Network Settings

About Device

Settings

Actions

Expert Mode:

Settings

Change WEB interface password:

Current password

New password

New password 2

Save password

Manager settings

Update settings:

Update check interval (minutes)

Other manager settings:

"BS-Dashboard" server startup method

Logger level

Set configs

Re-request configs

"BS-Dashboard" settings

The main features of working with the Web-interface:

1. If you change something in any menu, and then proceed to the next, these changes are saved in the client, but not saved on the gateway, and the edit icon appears in the menu block, where the unsaved changes remained.

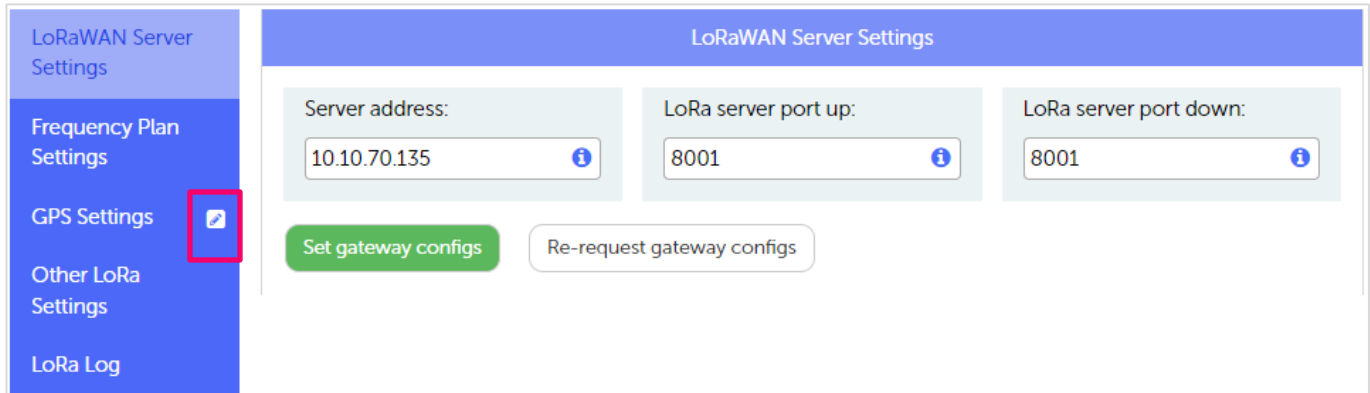

LoRaWAN Server Settings

Server address: 10.10.70.135

LoRa server port up: 8001

LoRa server port down: 8001

Set gateway configs Re-request gateway configs

2. To apply the settings changes at the gateway, you always need to click the "Save" button.
3. If you click the "Reset these settings" button, then all unsaved changes will be lost.
4. The buttons "Save" and "Reset settings" apply only to the group of parameters under which they are directly located.
5. The "Expert" mode allows you to see additional settings in the sections "Frequency plans", "LTE settings", "Network settings", "Settings" (only the "Manager settings" subsection) and "Actions".

GATEWAY SOFTWARE UPDATING

If the latest software updates are available, an exclamation mark icon will be displayed next to the "About Device" section. In this case, go to this section and click the "Update" button.

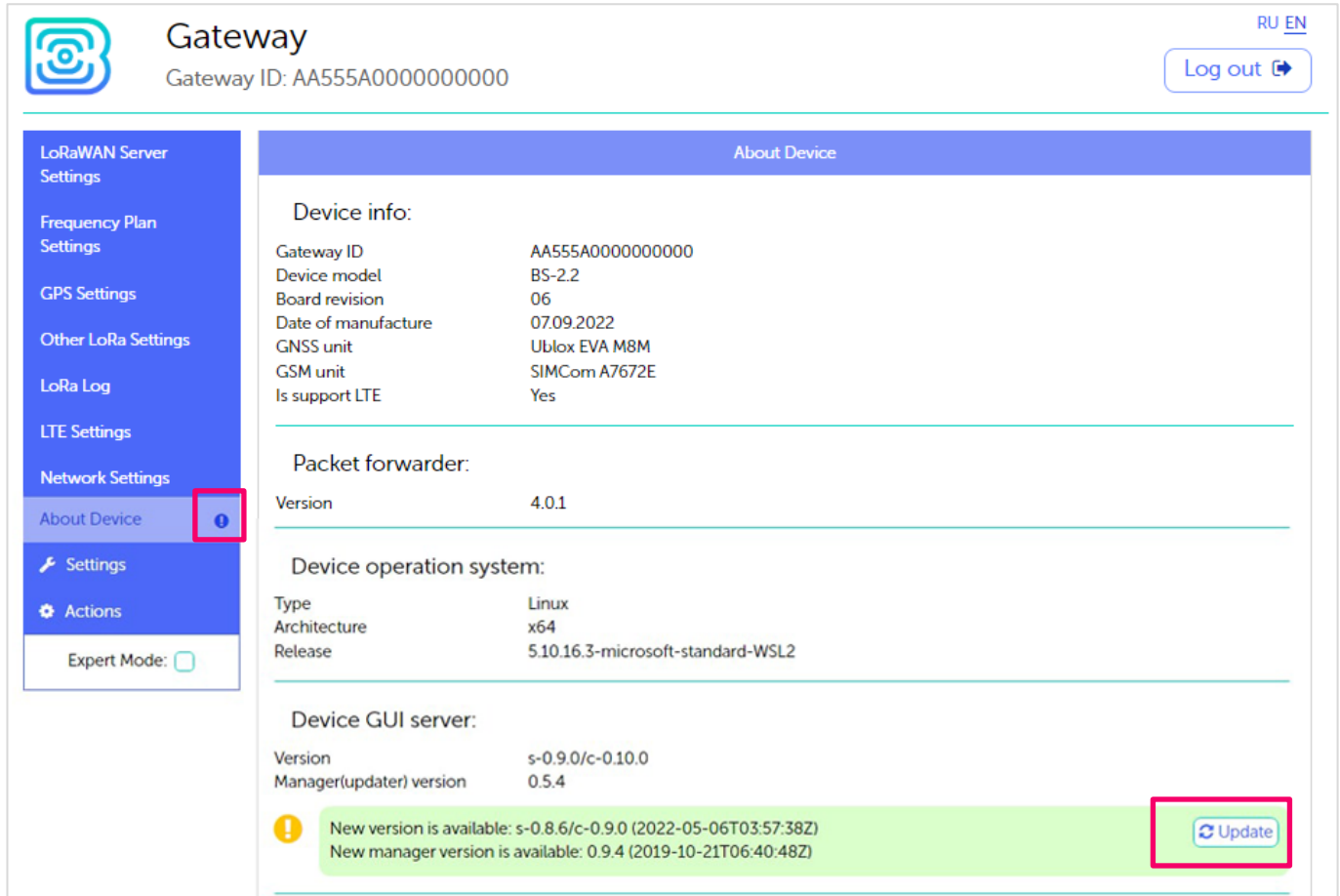

The screenshot shows the 'Gateway' web interface. The left sidebar contains navigation options: LoRaWAN Server Settings, Frequency Plan Settings, GPS Settings, Other LoRa Settings, LoRa Log, LTE Settings, Network Settings, About Device (highlighted with a red box and an exclamation mark icon), Settings, and Actions. At the bottom of the sidebar is an 'Expert Mode' toggle. The main content area is titled 'About Device' and displays the following information:

Device info:	
Gateway ID	AA555A0000000000
Device model	BS-2.2
Board revision	06
Date of manufacture	07.09.2022
GNSS unit	Ublox EVA M8M
GSM unit	SIMCom A7672E
Is support LTE	Yes

Packet forwarder:	
Version	4.0.1

Device operation system:	
Type	Linux
Architecture	x64
Release	5.10.16.3-microsoft-standard-WSL2

Device GUI server:	
Version	s-0.9.0/c-0.10.0
Manager(updater) version	0.5.4

At the bottom of the 'About Device' section, a green notification bar contains the following text:

! New version is available: s-0.8.6/c-0.9.0 (2022-05-06T03:57:38Z)
 New manager version is available: 0.9.4 (2019-10-21T06:40:48Z)

An 'Update' button with a refresh icon is located at the bottom right of the notification bar and is highlighted with a red box.

5 CONFIGURING OF THE GATEWAY WITH TERMINAL PROGRAM

GATEWAY CONNECTING TO THE COMPUTER – THE OPERATION BEGINING

Connection is possible, for example, with a free PuTTY program. There are two ways of connection to the gateway – with direct connection via USB or remote connection via SSH.

1. Connection via USB

In case of a USB connection, you need to connect the gateway to a personal computer with a mini-USB connector by a cable. Next, connect to a virtual COM port by installing the driver for MCP2200 or CP210x depends on installed USB-port on the board of the exact device. "Ports (COM and LPT)" menu appears at the device manager.

Search "USB Serial Port" in the "Ports" menu and see its number.

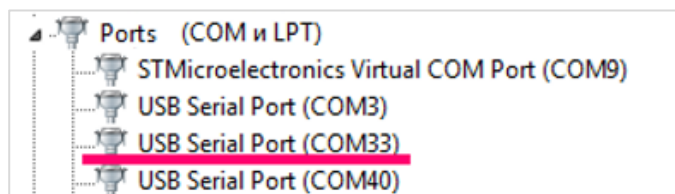

Open PuTTY, select Serial, enter number of the gateway virtual COM-port and speed (115200) in the corresponding fields.

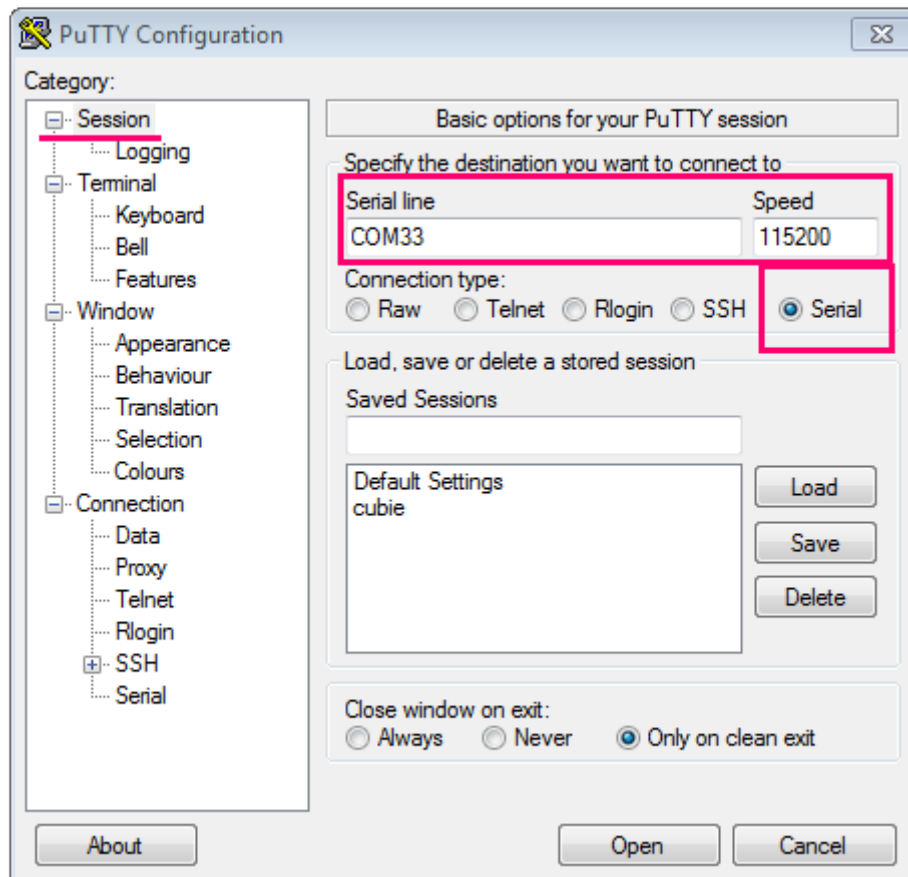

Press “Open” button.

2. Connection via SSH

The direct connection to gateway is not required in case of SSH connection. Select SSH connection in the PuTTY dialog box, enter the device's IP-address and port 22. By default, the device obtains an IP-address via DHCP when connected via Ethernet.

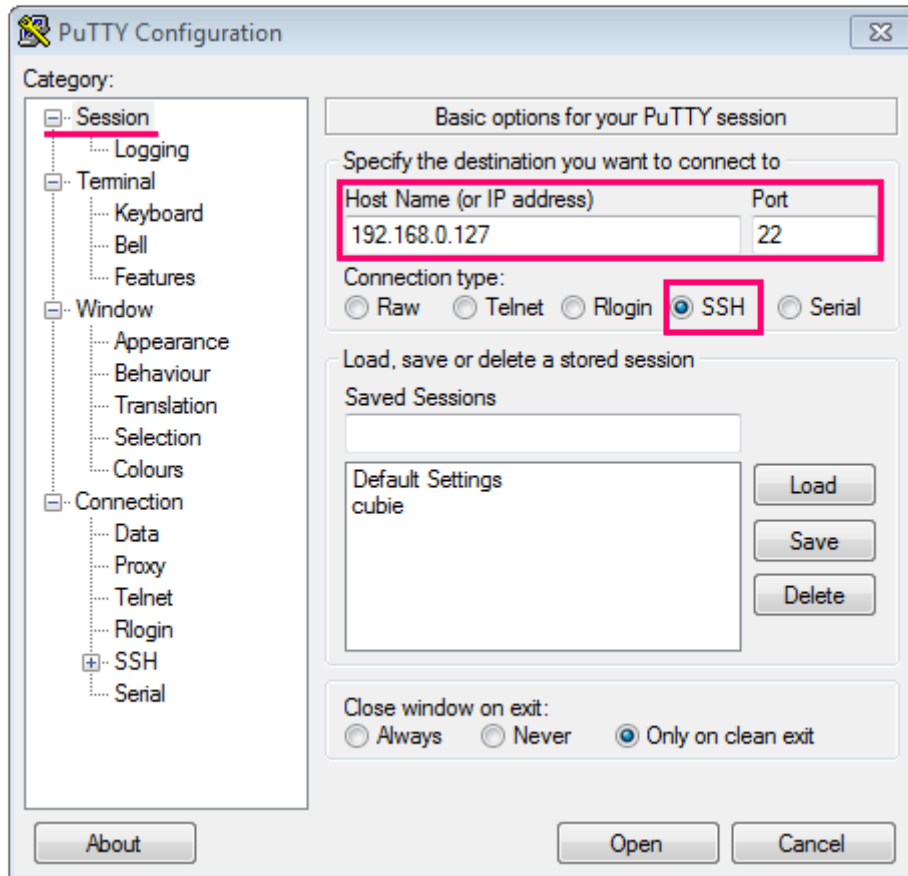

Press "Open" button.

After connecting to the gateway by one of the methods, PuTTY terminal window appears where you should enter login and password. By default, login *root* and password *temppwd* (symbols not displaying while entering the password) are used for connection to the

gateway. At the first connection, it is recommended to change the password for individual access.



By default, a user with root rights is denied ssh login, and therefore, ssh login must be performed under the admin user, the password remains the default.

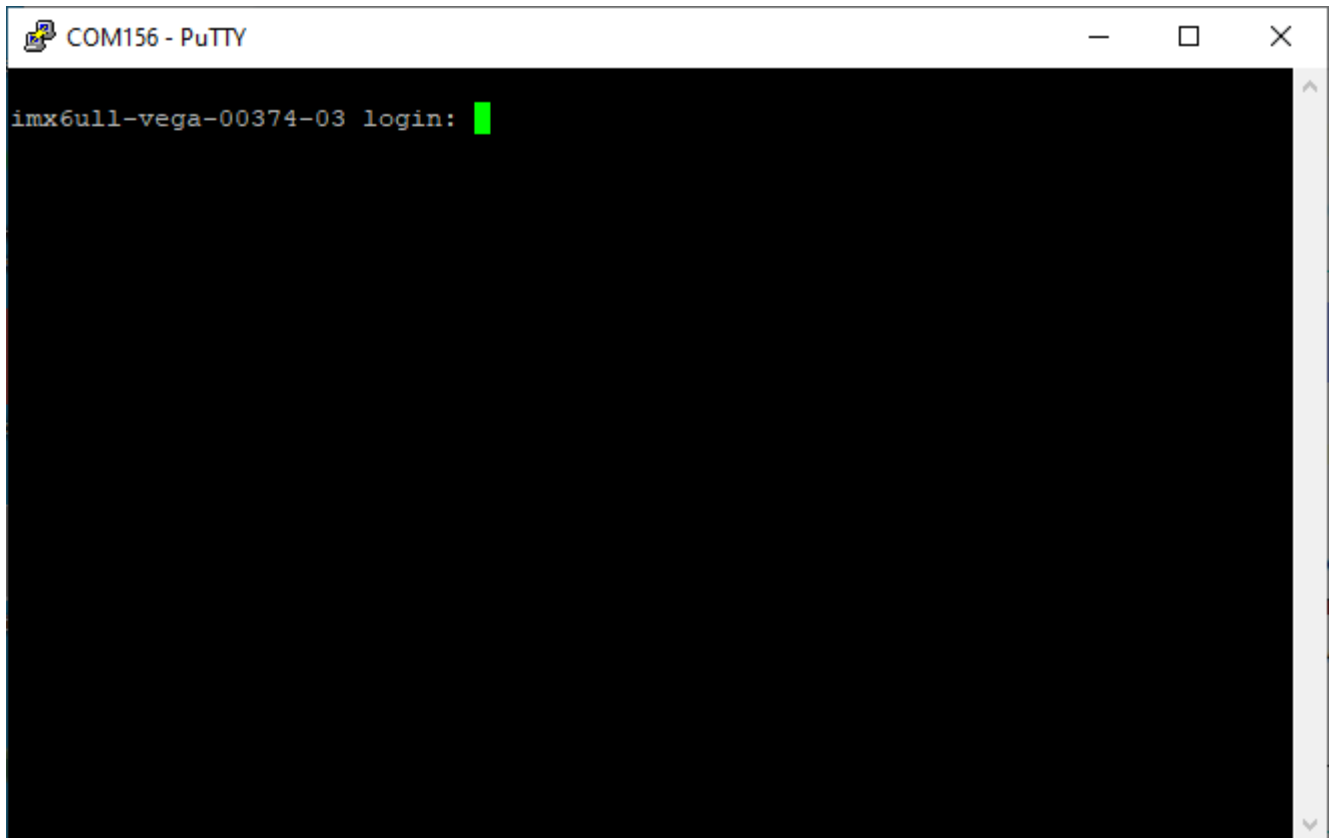

```
COM156 - PuTTY  
imx6ull-vega-00374-03 login: █
```

Now the configuration can be carrying out.

OPERATION WITH THE CONFIGURATION FILE

Packet forwarder starts automatically when the system starts. Before the gateway configuring, stop Packet forwarder by entering command:

```
systemctl stop lora_pkt_fwd
```

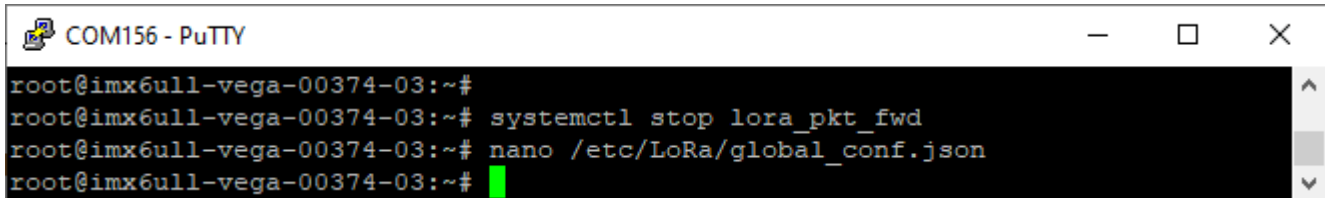

```
COM156 - PuTTY
root@imx6ull-vega-00374-03:~#
root@imx6ull-vega-00374-03:~# systemctl stop lora_pkt_fwd
root@imx6ull-vega-00374-03:~# nano /etc/LoRa/global_conf.json
root@imx6ull-vega-00374-03:~#
```

Configuration file `global_conf.json` is in the directory `cd /etc/LoRa/` – it may contain frequency band, the gateway ID, IP-address and server ports settings.

Enter the command, containing the required configuration file to change the settings.

After all changes completed enter the command:

```
systemctl start lora_pkt_fwd
```

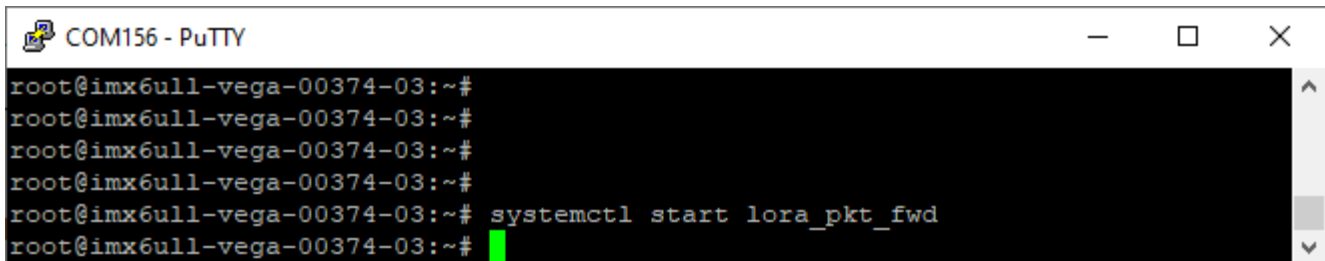

```
COM156 - PuTTY
root@imx6ull-vega-00374-03:~#
root@imx6ull-vega-00374-03:~#
root@imx6ull-vega-00374-03:~#
root@imx6ull-vega-00374-03:~#
root@imx6ull-vega-00374-03:~# systemctl start lora_pkt_fwd
root@imx6ull-vega-00374-03:~#
```

Packet forwarder will automatically start with new settings.



To connect the gateway to the server, you must use the UDP port specified in the server configuration file. On the gateway, the port configuration is in the `global_conf.json` file

In the `global_conf.json` file, the UDP port settings are in the `gateway_conf` section, there are `server_port_up` and `server_port_down` parameters.

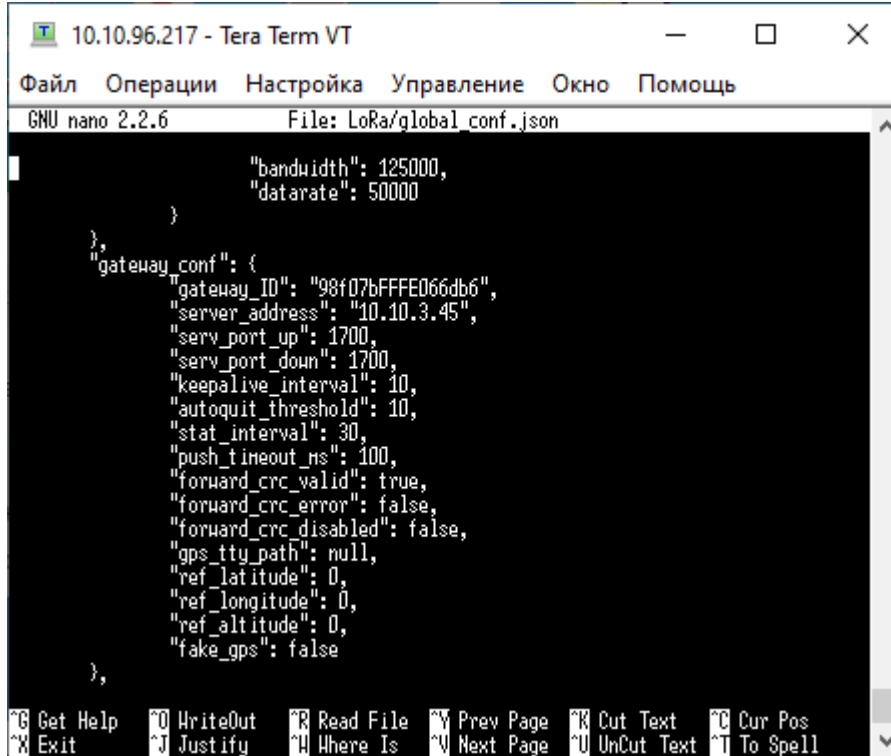

```

10.10.96.217 - Tera Term VT
Файл  Операции  Настройка  Управление  Окно  Помощь
GNU nano 2.2.6      File: LoRa/global_conf.json

        "bandwidth": 125000,
        "datarate": 50000
    },
    "gateway_conf": {
        "gateway_ID": "98f07bFFFE066db6",
        "server_address": "10.10.3.45",
        "serv_port_up": 1700,
        "serv_port_down": 1700,
        "keepalive_interval": 10,
        "autoquit_threshold": 10,
        "stat_interval": 30,
        "push_timeout_ms": 100,
        "forward_crc_valid": true,
        "forward_crc_error": false,
        "forward_crc_disabled": false,
        "gps_tty_path": null,
        "ref_latitude": 0,
        "ref_longitude": 0,
        "ref_altitude": 0,
        "fake_gps": false
    },

```

In order to communicate with the server correctly, you should make sure that these UDP port parameters correspond to those specified in the server configuration file (see details in the «IoT Vega Server Manual»).

To replace configuration file (for example, for change frequency plan) you need to make the following steps:

1. Go to Packet forwarder directory by the command:

```
cd /etc/LoRa/
```

2. If there is no file with the required frequency plan in the specified directory, then download it from the FTP storage using the command (following command is exactly for that file):

For BS-1.2

wget

```
ftp://lora_guest:vnm\$4JHW@178.208.75.230:21/BS_x.2/rev.6/BS_1.2_rev.6/global_conf_
RU868.json
```

For BS-2.2

wget

```
ftp://lora_guest:vnm\$4JHW@178.208.75.230:21/BS_x.2/rev.6/BS_2.2_rev.6/global_conf
_RU868.json
```

3. Make a copy of downloaded file (global_conf_EU868 in our example) with a new name global_conf.json by the command:

```
cp EU868_global_conf.json global_conf.json
```

4. Open file global_conf.json by the command:

```
nano LoRa/global_conf.json
```

and specify parameters, - *gateway_ID*, *server_address*, *serv_port_up*, *serv_port_down*, and then save and close the file.

Parameter *gateway_ID* is formed out of gateway MAC address and "FFFE" symbols. For example:

To get gateway MAC address you need to enter a command **ifconfig**

```

root@am335x-evm:~# ifconfig
eth0      Link encap:Ethernet  HWaddr 98:F0:7B:A7:55:58
          inet addr:10.10.70.174 Bcast:0.0.0.0 Mask:255.255.255.0
          UP BROADCAST RUNNING MULTICAST  MTU:1500  Metric:1
          RX packets:6774 errors:0 dropped:0 overruns:0 frame:0
          TX packets:2803 errors:0 dropped:0 overruns:0 carrier:0
          collisions:0 txqueuelen:1000
          RX bytes:571437 (558.0 KiB)  TX bytes:359977 (351.5 KiB)
          Interrupt:56

lo        Link encap:Local Loopback
          inet addr:127.0.0.1  Mask:255.0.0.0
          UP LOOPBACK RUNNING  MTU:65536  Metric:1
          RX packets:428 errors:0 dropped:0 overruns:0 frame:0
          TX packets:428 errors:0 dropped:0 overruns:0 carrier:0
          collisions:0 txqueuelen:0
          RX bytes:21400 (20.8 KiB)  TX bytes:21400 (20.8 KiB)
    
```

In our example MAC address is: **98:F0:7B:A7:55:58**.

Then you need to copy that MAC address, delete ":" symbols and put "FFFE" at the middle of line.

Example of ready *gateway_ID*: **98F07BFFFEA75558**

In order to do this through a script, you need to run the **update_gwid.sh** command

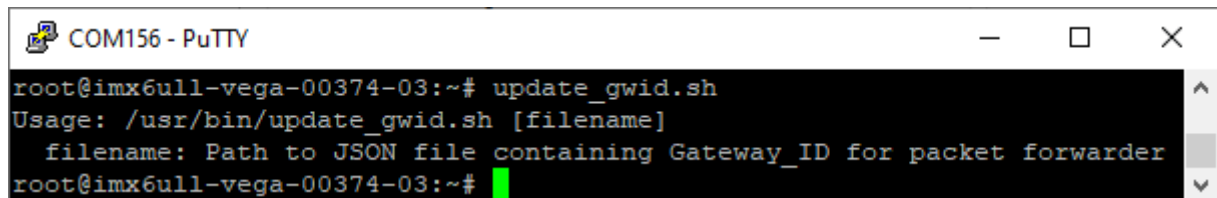

```

COM156 - PuTTY
root@imx6ull-vega-00374-03:~# update_gwid.sh
Usage: /usr/bin/update_gwid.sh [filename]
       filename: Path to JSON file containing Gateway_ID for packet forwarder
root@imx6ull-vega-00374-03:~#
    
```

5. Restart gateway by the command: **reboot**

CONFIGURATION OF A STATIC IP-ADDRESS FOR THE GATEWAY

Configuration of a static IP is carrying out with the terminal program in the following way:

1. After connecting to the gateway, enter login and password in the PuTTY terminal window.
2. Open file `nano cd /etc/systemd/network/80-wired.network/` and modify it:

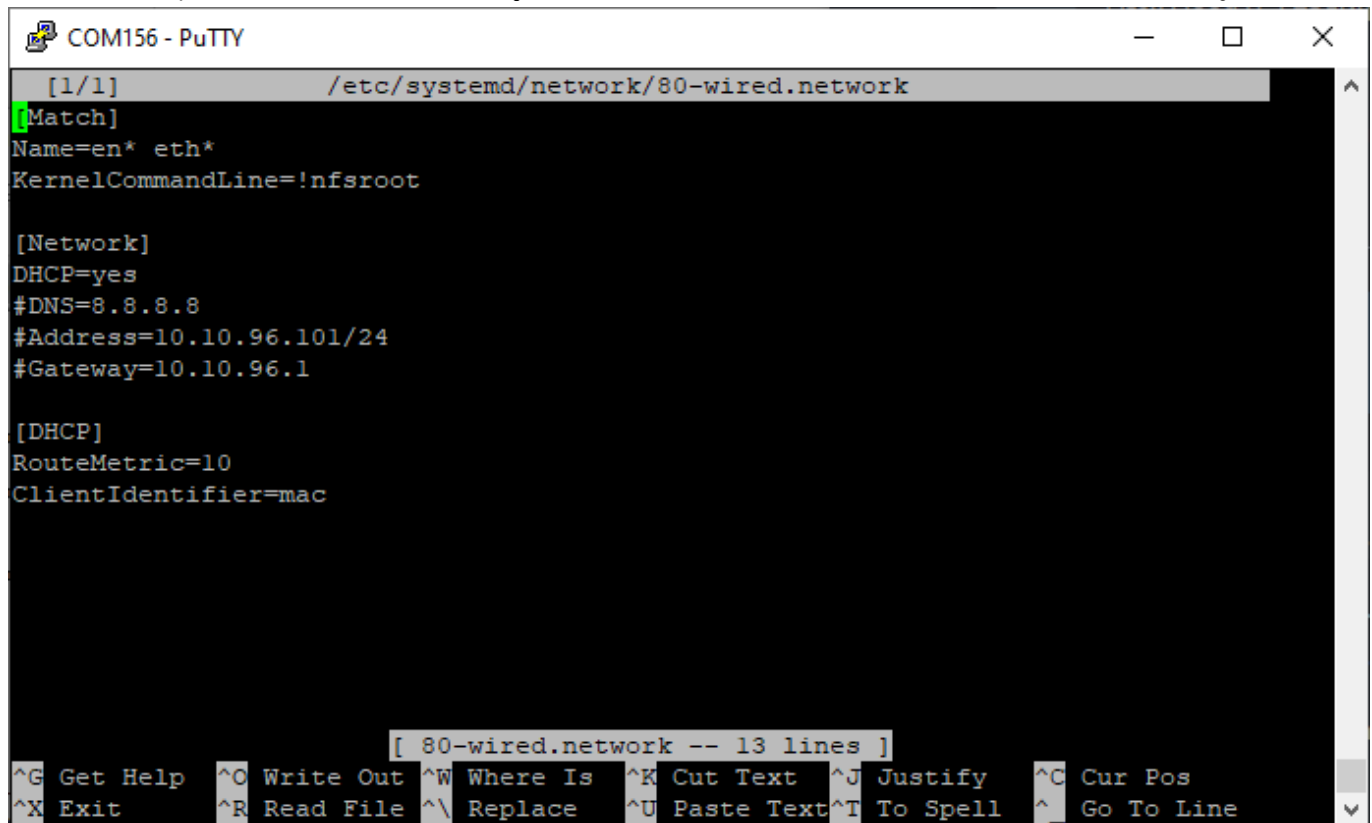

```
COM156 - PuTTY
[1/1] /etc/systemd/network/80-wired.network
[Match]
Name=en* eth*
KernelCommandLine=!nfsroot

[Network]
DHCP=yes
#DNS=8.8.8.8
#Address=10.10.96.101/24
#Gateway=10.10.96.1

[DHCP]
RouteMetric=10
ClientIdentifier=mac

[ 80-wired.network -- 13 lines ]
^G Get Help ^O Write Out ^W Where Is ^K Cut Text ^J Justify ^C Cur Pos
^X Exit ^R Read File ^\ Replace ^U Paste Text ^T To Spell ^ _ Go To Line
```

cd pp cd ..

- That are strings exactly:

```
[Network]
DHCP=yes
#DNS=8.8.8.8
#Address=10.10.96.101/24
#Gateway=10.10.96.1
```

- To work in static IP mode, comment the 2nd string.
- Uncomment 3-5th strings and also specify your address, netmask and gateway parameters - the result is in the screenshot below (but other address values):

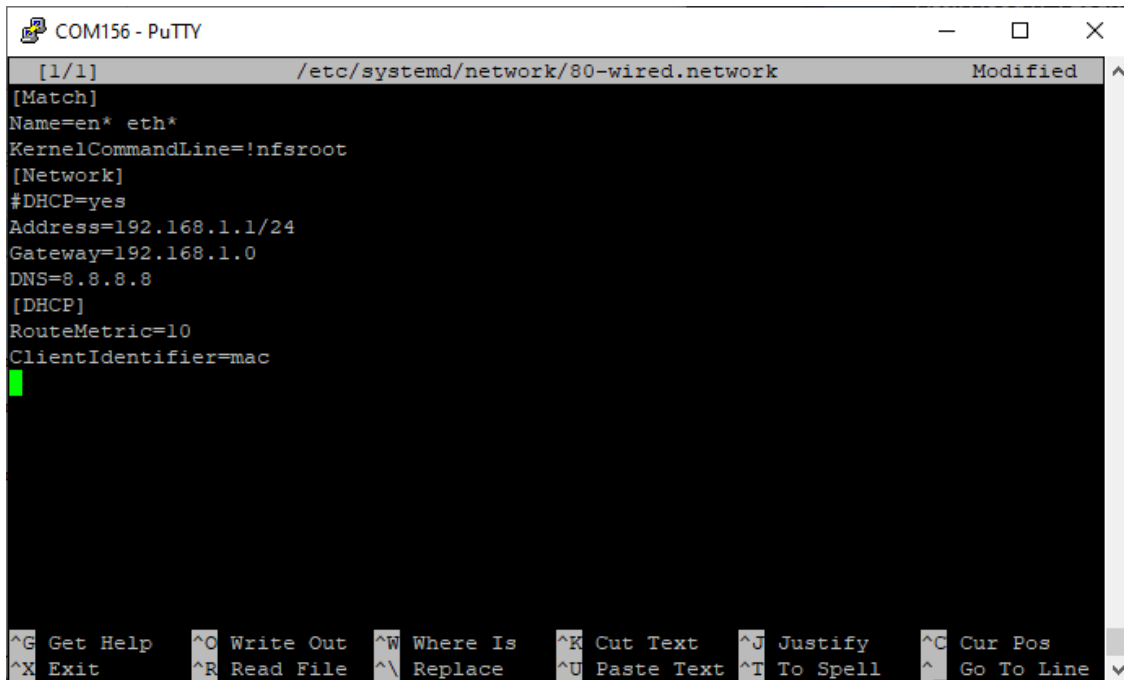

```
COM156 - PuTTY
[1/1] /etc/systemd/network/80-wired.network Modified
[Match]
Name=en* eth*
KernelCommandLine=!nfsroot
[Network]
#DHCP=yes
Address=192.168.1.1/24
Gateway=192.168.1.0
DNS=8.8.8.8
[DHCP]
RouteMetric=10
ClientIdentifier=mac
```

[^]G Get Help [^]O Write Out [^]W Where Is [^]K Cut Text [^]J Justify [^]C Cur Pos
[^]X Exit [^]R Read File [^]\ Replace [^]U Paste Text [^]T To Spell [^] Go To Line



**In that example shown setting of the static IP-address 192.168.1.1 and gateway 192.168.1.0
 You need to change those values to others, which are necessary to your own case**

- Type **reboot** in command line for gateway restarting with new settings.

7. Going back is similar.

BS-2.2 GATEWAY SETTING UP FOR LTE OPERATION

Gateway **BS-2.2** setting up for LTE operation using the terminal program is in the following order for each SIM separately:

Check, that in files `nano provider1-connect-chat` и `nano provider2-connect-chat` located `cd /etc/ppp/` there are strings highlighted in red:

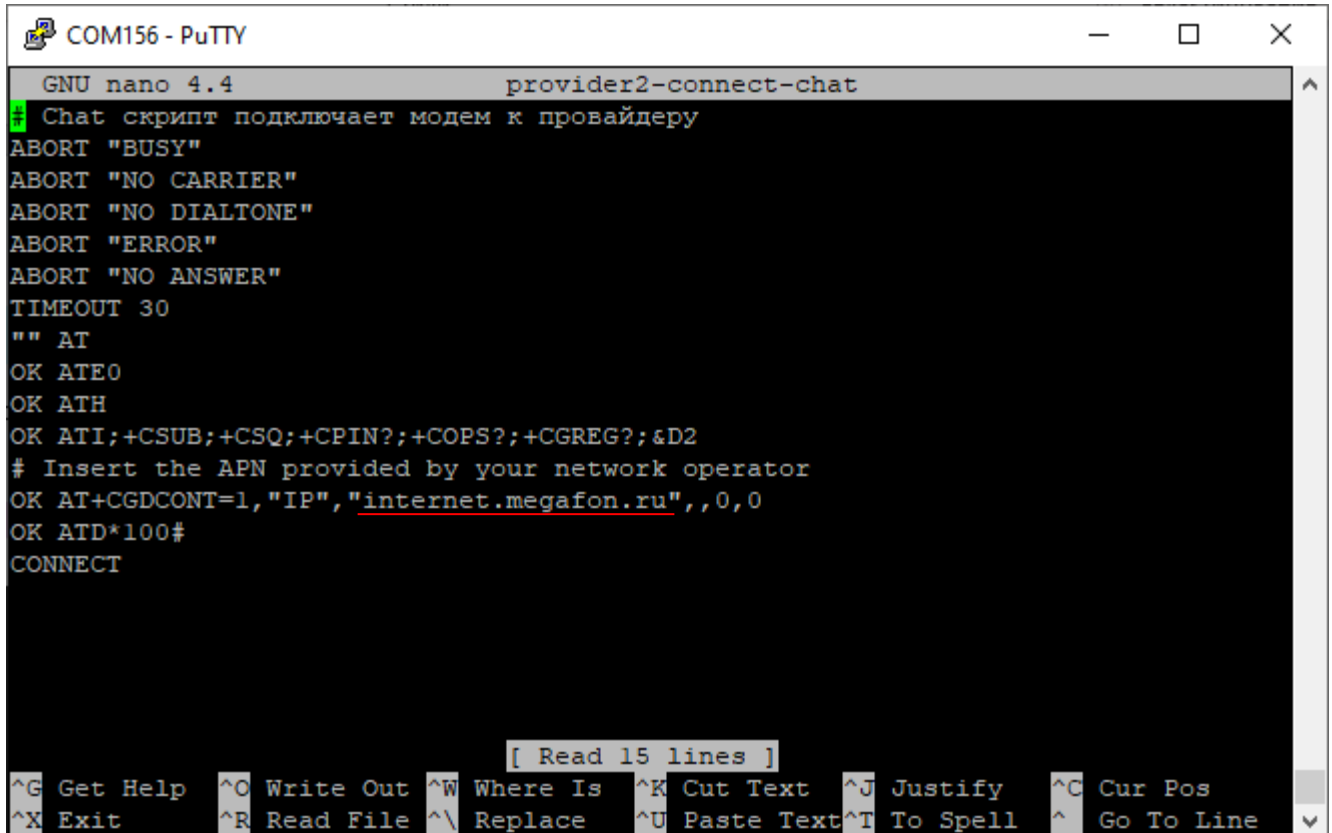

```

COM156 - PuTTY
GNU nano 4.4 provider2-connect-chat
Chat скрипт подключает модем к провайдеру
ABORT "BUSY"
ABORT "NO CARRIER"
ABORT "NO DIALTONE"
ABORT "ERROR"
ABORT "NO ANSWER"
TIMEOUT 30
"" AT
OK ATE0
OK ATH
OK ATI;+CSUB;+CSQ;+CPIN?;+COPS?;+CGREG?;&D2
# Insert the APN provided by your network operator
OK AT+CGDCONT=1,"IP","internet.megafon.ru",,0,0
OK ATD*100#
CONNECT

[ Read 15 lines ]
^G Get Help ^O Write Out ^W Where Is ^K Cut Text ^J Justify ^C Cur Pos
^X Exit ^R Read File ^\ Replace ^U Paste Text ^T To Spell ^_ Go To Line
    
```

where `"internet.megafon.ru"` is APN cellular operator. Change APN value according to APN cellular operator.



**In that example shown LTE setting for Megafon cellular operator
You need to change those values to others, which are necessary to your
own case**

The username and password are written in the **pap-secrets** file located along the path
`cd /etc/ppp/`

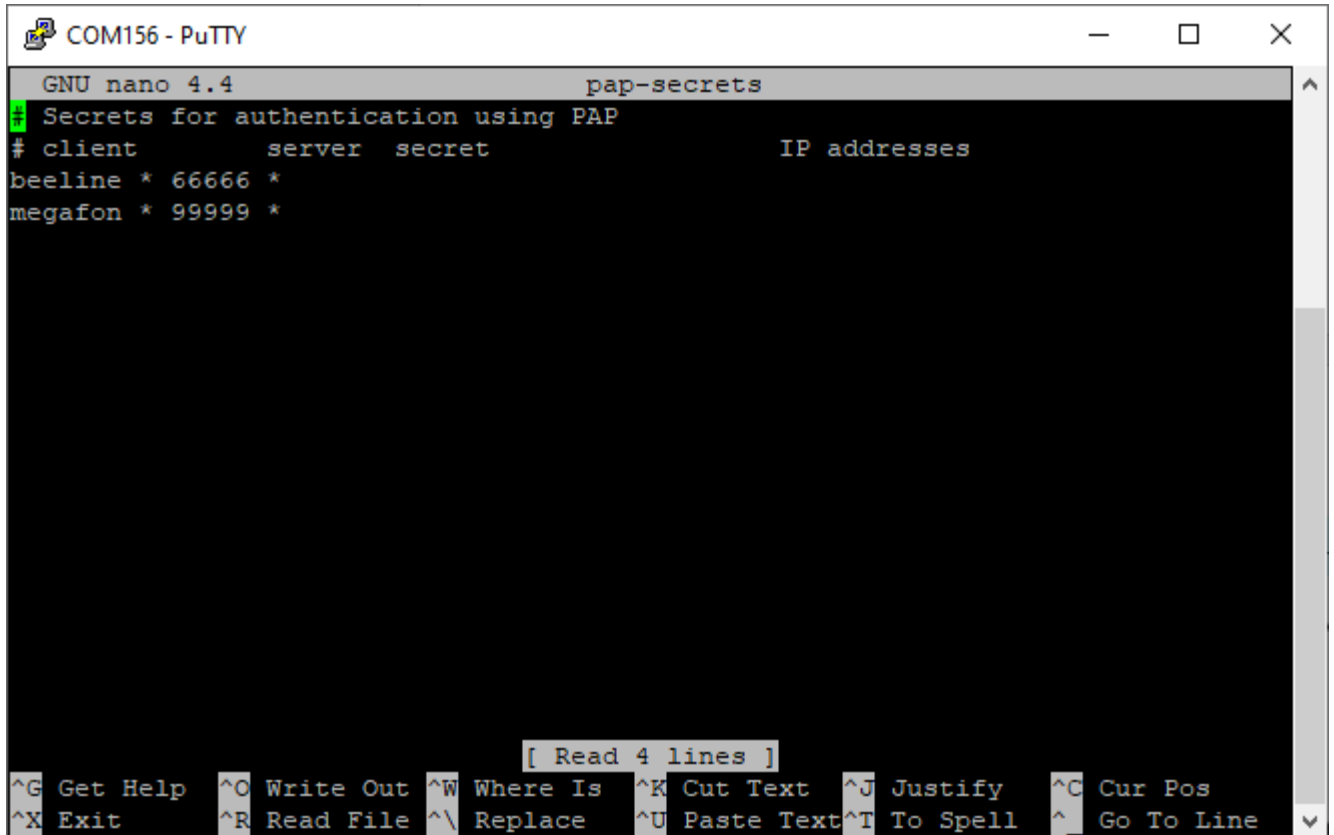

```
COM156 - PuTTY
GNU nano 4.4 pap-secrets
Secrets for authentication using PAP
# client server secret IP addresses
beeline * 66666 *
megafon * 99999 *

[ Read 4 lines ]
^G Get Help ^O Write Out ^W Where Is ^K Cut Text ^J Justify ^C Cur Pos
^X Exit ^R Read File ^\ Replace ^U Paste Text ^T To Spell ^_ Go To Line
```

Where **beeline** is the login and **66666** is the password.



Password and Username fields could not be empty, if those parameters are not used by the cellular operator, then you may to enter 'internet' word at both fields for example



BS-2.2 gateways are switching between Ethernet and LTE automatically



If you use such two communication channels as Ethernet and LTE at the same time you should to remember that Ethernet has a priority for communication and LTE used as a backup option if gateway cannot communicate with the server via Ethernet

For recommendations for gateways using white IP, see below.

RECOMMENDATIONS FOR GATEWAY USING IN WHITE IP NET

In case the BS is used in network with white IP, it is recommended to change the standard port numbers of ssh and telnet to others. This should be considered while port forwarding. The steps sequence for changing BS dropbear and telnetd ports is described below.

To change ssh port:

1. Enter at the command line of the terminal program
nano /lib/systemd/system/dropbear.socket
2. Open file **nano /lib/systemd/system/dropbear.socket**

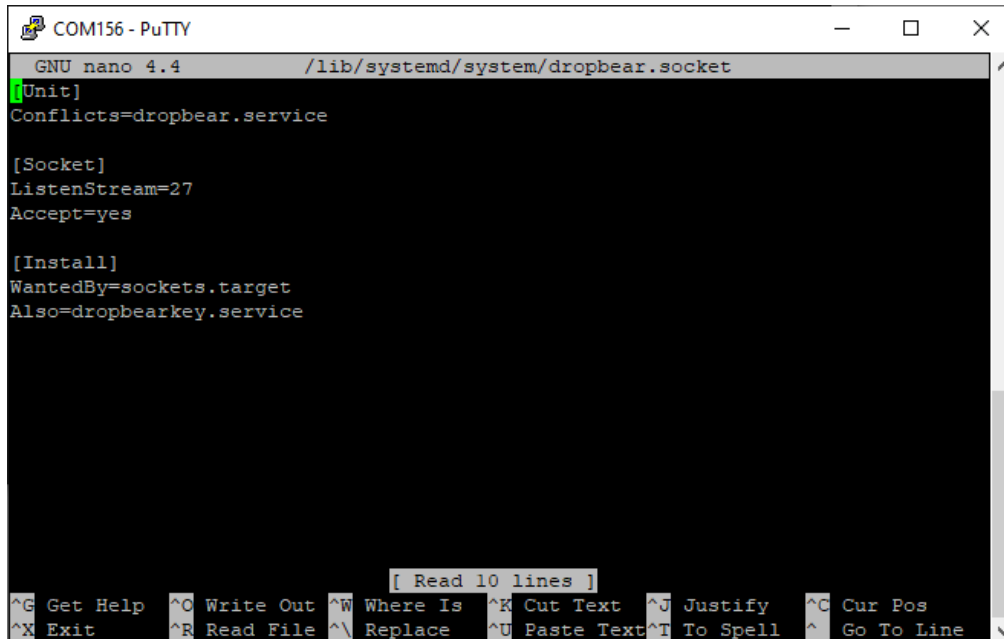

```
COM156 - PuTTY
GNU nano 4.4 /lib/systemd/system/dropbear.socket
[Unit]
Conflicts=dropbear.service

[Socket]
ListenStream=27
Accept=yes

[Install]
WantedBy=sockets.target
Also=dropbearkey.service

[ Read 10 lines ]
^G Get Help ^O Write Out ^W Where Is ^K Cut Text ^J Justify ^C Cur Pos
^X Exit ^R Read File ^\ Replace ^U Paste Text ^T To Spell ^_ Go To Line
```

3. Find string ListenStream=27 and change standard port «27» to another, then save the file.
4. Enter at the command line of the terminal program **systemctl daemon-reload** and restart **systemctl restart dropbear.socket**

The gateway has OpenVPN client. Configuring VPN connection is covered in a separate document by software developer.

6 SAFE OPERATION RECOMMENDATIONS

GENERAL RECOMMENDATIONS

Before starting work with the Vega BS, you should learn this Operation Manual (hereinafter referred to as the Manual).

This device is designed for LoRaWAN® network deployment in the 863-870 MHz range. Using the device for purposes other than those specified in this manual is a violation of the operating rules. The producer is not liable for any damage resulting from improper use of the device.

The Vega BS device should be operated by a trained person.



The device isn't intended for use by children or in areas where children may be present



**Prohibited:
independent repair of the device, making changes to the device design,
installation of any software (except for the producer's software)**

Unprofessionally performed repair work or installed third party software can result in device failure, personal injury, and property damage.



The producer does not assume liability for unpredictable effects resulting from the use of third party software on the device

ELECTRICAL SAFETY



Do not operate the device near an open flame or direct sunlight. Doing so may result in overheating and fire. The device should be used at air temperatures range from -40 °C (-40 F) to +70 °C (158 F)

If a fire is detected, immediately stop using the device and eliminate the fire. After that, the device should be sent to the producer for diagnostics (See the Warranty section for the producer's contacts).

Don't allow foreign objects to get into the device case during operation, as this may result in short circuits and fire. Don't operate the device with the case open or damaged.



Accidental damage to the power cable may result in electric shocks and faults that are not covered under the warranty terms

Prohibited to immerse the device case in water, it is not recommended to put it under water jets.



Don't touch wires, circuit boards, or the device enclosure with wet hands

Don't use the device after it has been exposed to water. Doing so may result in injury or damage to the device and cause it to malfunction. In such cases, contact the producer's technical support.

SAFETY RULES IN CASE OF DAMAGE TO THE ENCLOSURE

During normal operation of the device, the housing is not dangerous. If the case is mechanically damaged, sharp edges and corners may form, posing a potential hazard to the user. In this case, stop using the device and send it to the producer for replacement of the housing.

When operated in accordance with this manual, the device does not pose a danger to person.

RADIATION INFORMATION

When used correctly and following the installation recommendations, the device has no harmful effects on the person body and electrical equipment.

7 STORAGE AND TRANSPORTATION REQUIREMENTS

Vega BS gateways shall be stored in the original packaging in a dry room under conditions that do not allow direct contact with moisture at temperatures +5 °C to +40 °C and relative humidity less than 85 %. The devices must be protected against conductive dust, vapors of acids and alkalis as well as gases that cause corrosion and destroy insulation.

The devices are transported in the original packaging by all transport modes in covered vehicles in accordance with the rules of cargo transportation, operating on this type of transport, and technical conditions of loading and load securing.

During loading and unloading operations and transportation the boxes must not be exposed to sharp impacts and atmospheric precipitation.

The way of stacking the boxes with the product on the transportation vehicle should prevent their movement.

Transportation of the device without packing may result in its breakage.

The gateway transportation is permissible in covered freight compartments of all types at any distance at temperatures -40 °C to +85 °C.

8 CONTENT OF THE PACKAGE

The gateway delivered complete with:

Vega BS gateway – 1 pc.

PoE-injector³ – 1 pc.

Passport – 1 pc.

³ The presence of a PoE injector in the kit depends on the terms of delivery

9 WARRANTY

The manufacturer guarantees that the product complies with the current technical documentation, subject to the storage, transportation and operation conditions specified in the "User Manual".

The warranty period - 36 months from the date of sale, provided that the operating rules, as well as maintenance condition and storage conditions are observed.

In the event of case it is established that the failure of the device has occurred due to reasons beyond the control of the consumer and is related to a defect in materials or violation of technological processes during production, which ultimately makes it impossible to continue using the device, the manufacturer is obliged to provide repair services or replace the defective device or its components within the warranty period.

Technical examination or diagnosis by the producer's staff may be required to determine the cause of failure or nature of damage. Replacement or warranty repair is performed after the producer's confirmation of compliance with the warranty requirements.

The warranty does not apply to PoE-injector.

The manufacturer does not bear warranty obligations in the event of a product failure if:

- ⦿ the product does not have the passport;
- ⦿ the passport does not have an TCD stamp and / or there is no sticker with information about the device;
- ⦿ the serial number (MAC) printed on the product differs from the serial number (MAC) specified in the passport;
- ⦿ the product has been subject to alterations in the design which are not provided for in the operational documentation;

- ⦿ the product has mechanical, electrical and / or other damage and defects arising from violation of the conditions of transportation, storage and operation;
- ⦿ the product has traces of repair outside the manufacturer's service center;
- ⦿ the components of the product have internal damage caused by the ingress of foreign objects / liquids and / or natural disasters (flood, fire, etc.);
- ⦿ natural wear and tear;
- ⦿ storage and operating regulations have been violated;
- ⦿ the permissible loads on the device have been exceeded.

The average service life of the product is 5 years.

In the event of a warranty claim, contact the service center:

119A, Bol'shevistskaya Str., Novosibirsk, 630009, Russia.

Tel.: +7 (383) 206-41-35.

e-mail: remont@vega-absolute.ru

DOCUMENT INFORMATION	
Title	Gateway Vega BS
Document type	Manual – Translation from Russian
Revision and date	36 of 24 March 2026

Revision History

Revision	Date	Name	Comments
01	27.04.2017	KEV	Document creation date
02	15.05.2017	PKP	Minor edits
03	18.05.2017	KEV	General manual on BS-1 and BS-2
04	13.06.2017	KEV	Edits in the content of the package
05	14.06.2017	KEV	Part « Configuration » was edit, A5 format
06	14.08.2017	KEV	Antenna mounting recommendation was added
07	16.08.2017	KEV	Part « Operation » was edit
08	28.08.2017	KEV	Minor edits in the « Configuration of a static IP-adress »
09	27.09.2017	KEV	«SIM card installation» was added
10	02.11.2017	KEV	Parts « Gateway setting up for 3G operation », « Recommendations » were added, new format
11	29.06.2018	KEV	Vega BS-1.2 and Vega BS-2.2 description is added, content of the package is changed, working temperatures are changed
12	23.08.2018	KEV	Minor changes
13	18.09.2018	KEV	Minor changes
14	24.10.2018	KEV	Ethernet type added in specification

15	20.11.2018	KEV	Changes in part « Configuration of a static IP-address », adds to part « Start of work »
16	29.04.2019	KEV	Operating position of DIP-switches changed (fig. 3.3)
17	14.11.2019	KEV	There is a new part added which describes gateway interface
18	05.12.2019	KEV	File links changed on the page 28 and 29 .
19	26.03.2020	KEV	Specification for 3G modem is updated
20	06.10.2020	KEV	Now the setting for 3G operation is only for BS-2.2
21	19.10.2020	KEV	Power consumption is changed
22	28.06.2021	KEV	Scheduled revision of document
23	14.09.2021	KEV	Note has been added at 15 th page
24	29.10.2021	KMA	Information about the BS-2.2 LTE version has been added, edits in the " SIM-card installation "
25	13.01.2022	KMA	Minor edits
26	13.04.2022	KEV	Scheduled revision, new parts , new board version, changes in part 5 (config file has changed the directory)
27	23.08.2022	KMA	Warranty clarified
28	10.11.2022	KEV	New parts: software updating and maintenance recommendations
29	15.12.2022	KMA	3G has been removed
30	27.04.2023	KMA	StrongSwan support has been removed
31	02.05.2024	NEE	Minor edits to the "Technical Specifications" section
32	27.05.2024	NEE	Commenting on the Mounting Recommendations

33	10.07.2024	NEE	Edits were made to the section "Operation with the configuration file" on p. 35
34	29.08.2024	NEE	Changing the body size
35	04.12.2024	NEE	Replacing the minimum power indicator on p. 13
36	24.03.2026	NEE	Edits to the " Interface launch – the operation beginning " subsection on page 26, and updating the date on the last page



vega-absolute.ru

User Manual © Vega-Absolute OOO 2026